

## PRODUCT INSTALLATION GUIDE

**MODEL:** 8COMM  
**PRODUCT CODE:** 8COMMSFK  
**PRODUCT DESCRIPTION:** CouplerTec Commercial Heavy Duty Electronic Rustproofing System  
12V / 24V  
Eight Capacitive Couplers

### KIT CONTENTS:

ITEM	QTY
Couplertec Module	1
Capacitive Coupler	8
Capacitive Coupler Covers	8
Alcohol Cleaning Pad	8
Fuse Holder with Ring Terminal	1
Blade Fuse (2Amp)	1
Heat-Shrink Ring Terminal	3
Crimp Heat-Shrink Connector	17
Hex Head Self Tapping Screw	20

### PRODUCT TO BE SUPPLIED BY THE INSTALLER.

For installation of the CouplerTec System you will need to supply the following:

### PRODUCT REQUIRED

1. 4mm Double Insulated Auto Cable
2. Cable Ties
3. Split Loom
4. Neutral Cure Silicone

### TOOLS REQUIRED:

1. Power Drill
2. 6 mm Drill Bit
3. 8mm Socket (5/16")
4. Side Cutter
5. Wire Stripper
6. Crimping Tool
7. Heat Gun or Gas Torch

### **Installation Guide Video**



<http://bit.ly/1znHN3w>

**PLEASE READ THE FOLLOWING FITTING INSTRUCTIONS CAREFULLY BEFORE PROCEEDING TO INSTALL THE COUPLERTEC ELECTRONIC RUSTPROOFING SYSTEM.**

For **technical support** please contact us from **7 AM to 4 PM CET** on **business days** (Monday to Friday) by **phone 00 386 40 80 33 40** or send us an e-mail to **info@couplertec.si**.

### Step 1: Select a site to locate the Couplertec Module

The module should be mounted on the same side as the vehicles main/start battery. The module can be mounted either horizontally or vertically. Try and locate the module in a site that will not interfere with normal vehicle repair or maintenance, and preferably a site where the two LED indicators will be visible.

**IMPORTANT INFORMATION: DO NOT connect the Module to Auxiliary Batteries!**

### Step 2: Selecting sites to locate the Capacitive Couplers

The Capacitive Coupler sites should be evenly located over the vehicle/machine with a minimum distance of 1.5m between Capacitive Coupler sites. Locate the Capacitive Couplers as high as possible on the body of the Vehicle /Machine in positions where they will not be subjected to any possible damage.

**The Capacitive Coupler site must be:**

- **A painted metal surface which is part of the vehicles main structure e.g. Cab, Chassis or Body**
- **Flat (no contoured surfaces or indentations)**
- **Large enough to accommodate the entire surface area of the Capacitive Coupler**
- **Free of holes**
- **Free of joins in the metal work**
- **Free of spot welds, welding slag/spikes**
- **Well painted with no scratches (if in doubt, lightly sand and apply two coats of quick dry enamel paint to the area).**

(FIGURE: 1): Example diagram of a truck installation

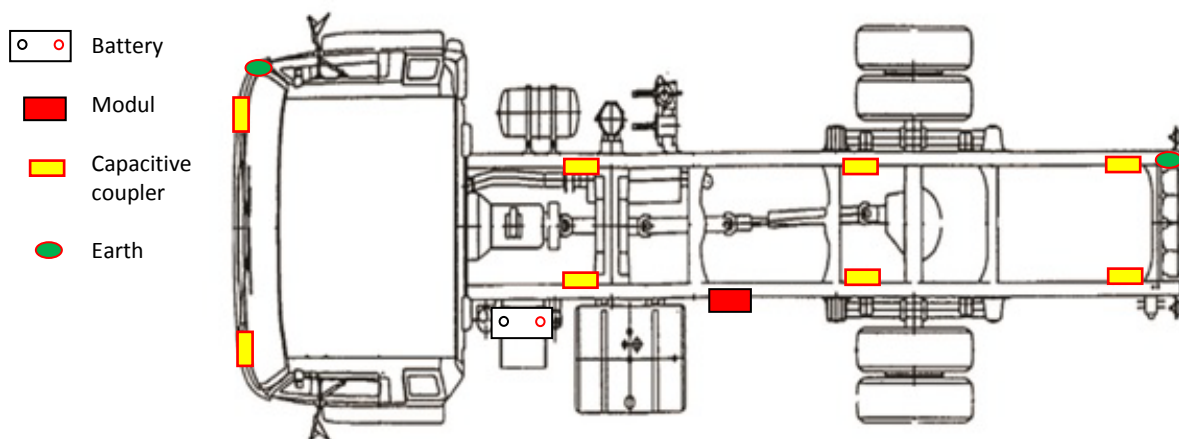

### Step 3: Fitting the CouplerTec Module

Drill two 6mm holes in each of the modules two base wings. (refer figure: 2)

Affix the module to the vehicle/ machine using the Hex Head Self Tapping Screws. (before affixing, ensure that there is nothing behind the location that can be damaged by the self tapping screws).

(FIGURE: 2)

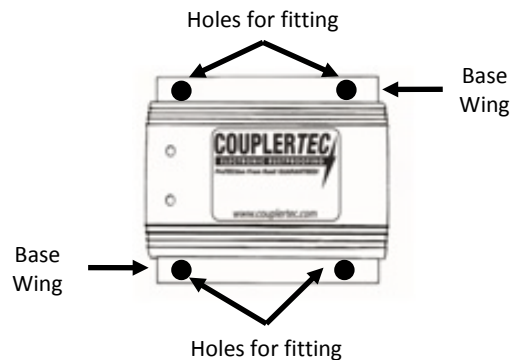

### Step 4: Connecting the Module to the battery/batteries

Connect the pre-wired half of the fuse holder (the ring terminal) to the positive (+) battery terminal.

For 24V set-up refer to figure 4 to determine the correct (+) battery terminal.

Route the RED wire from the Module to the fuse holder, cut to length and crimp to the other half of the fuse holder using a crimp heat-shrink connector. Use a heat gun to seal the heat-shrink connector.

(FIGURE: 3): 12V BATTERY SET-UP

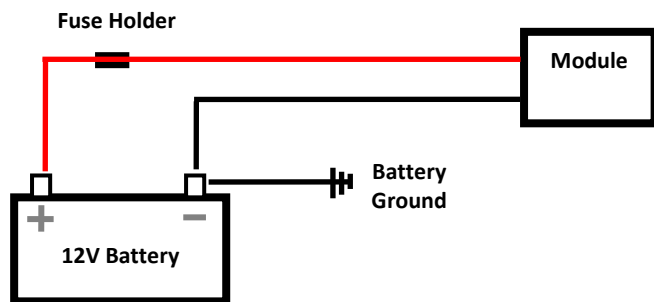

**IMPORTANT INFORMATION: DO NOT insert the fuse at this stage!**

Route the BLACK wire from the Module to the negative (-) battery terminal and cut to length, crimp on a Ring Terminal. Use a heat gun to seal the heat-shrink on the ring terminal connection.

Connect the ring terminal to the negative (-) battery terminal. (for 24V set-up refer to figure 4 to determine the correct (-) battery terminal)

(FIGURE: 4): 24V BATTERY SET-UP

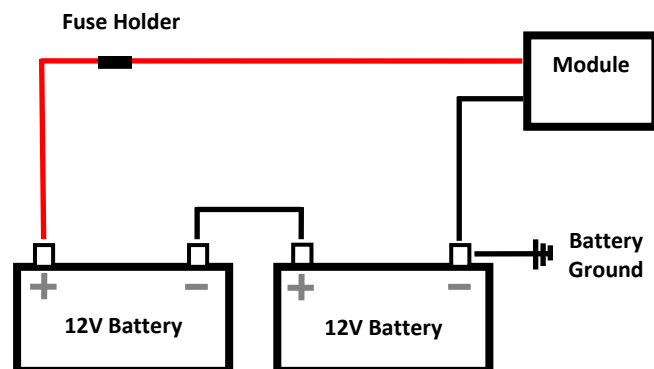

**IMPORTANT INFORMATION: Be sure to avoid positioning wires too close to hot or moving parts that may melt or pinch the wires. Protect all wiring with split loom. Ensure that all wiring cannot be damaged or torn off in normal working environments. Secure all wiring firmly with cable ties or equivalent alternative.**

### Step 5: Routing the BLUE Capacitive Coupler wires

The BLUE Capacitive Coupler Wires should be routed towards the Capacitive Coupler sites at the FRONT of the vehicle/machine. (refer to figure: 5)

Route each BLUE wire from the Module towards the selected Capacitive Coupler site and cut to length, or extend if necessary using 4mm Auto wire.

Connect the BLUE wire (or extended wire) to the Capacitive Coupler wire using the supplied crimp heat-shrink connector. After crimping the connection, use a heat gun to seal the heat-shrink connection.

### Step 6: Fit Capacitive Coupler and Capacitive Coupler Covers

Refer to Page 7 for fitting instructions.

### Step 7: Routing the GREEN / YELLOW Earth wire

The GREEN/YELLOW wire MUST be routed in the same direction as the BLUE wires. Find an existing screw/bolt at the very FRONT extremity of the vehicle/machine to earth the wire.

Route the GREEN/YELLOW wire to the selected location, extend the wire if necessary using 4mm auto cable, crimp on a heat-shrink ring terminal and then seal the crimp connection using a heat gun. Terminate the wire under the existing screw/bolt ensuring a good earth. (refer to figure: 5)

(FIGURE: 5): Example diagram for a Truck installation - BLUE wires running to the FRONT Capacitive Coupler locations.

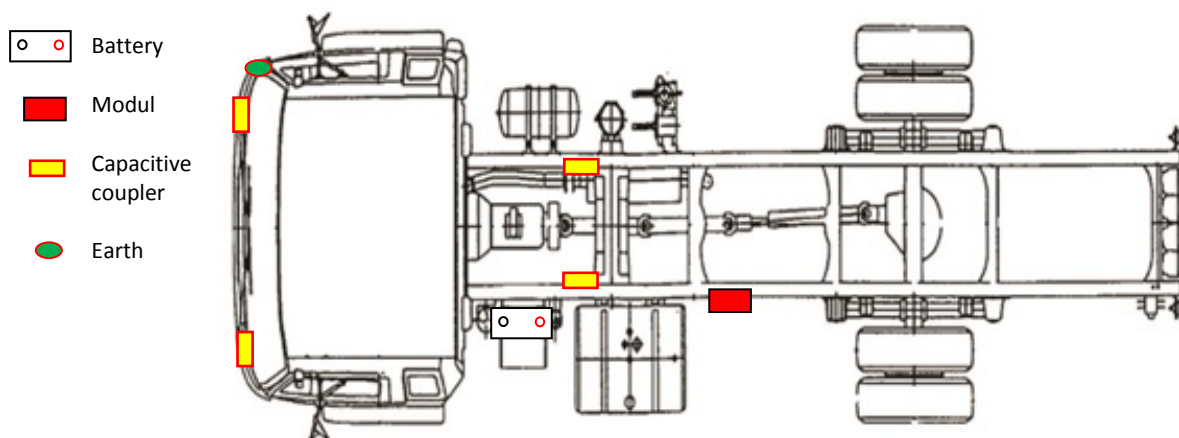

**IMPORTANT INFORMATION:** Be sure to avoid positioning wires too close to hot or moving parts that may melt or pinch the wires. Protect all wiring with split loom. Ensure that all wiring cannot be damaged or torn off in normal working environments. Secure all wiring firmly with cable ties or equivalent alternative.

### Step 8: Routing the WHITE Capacitive Coupler wires

The WHITE Capacitive Coupler Wires should be routed towards the Capacitive Coupler sites at the REAR of the vehicle/machine. (refer to figure: 5)

Route each WHITE wire from the Module towards the selected Capacitive Coupler site and cut to length, or extend if necessary using 4mm Auto wire.

Connect the WHITE wire (or extended wire) to the Capacitive Coupler wire using the supplied crimp heat-shrink connector. After crimping the connection, use a heat gun to seal the heat-shrink connection.

**Step 9: Fit Capacitive Couplers and Capacitive Coupler Covers** → Refer: Fitting instructions (p7).

### Step 10: Routing the GREEN Earth wire

The GREEN wire MUST be routed in the same direction as the WHITE wires. Find an existing screw/bolt at the very REAR extremity of the vehicle/machine to earth the wire. (refer to figure: 5)

Route the GREEN wire to the selected location, extend the wire if necessary using 4mm auto cable, crimp on a heat-shrink ring terminal and then seal the crimp connection using a heat gun. Terminate the wire under the existing screw/bolt ensuring a good earth.

(FIGURE: 6): Example diagram for a Truck installation - WHITE wires running to the REAR Capacitive Coupler locations.

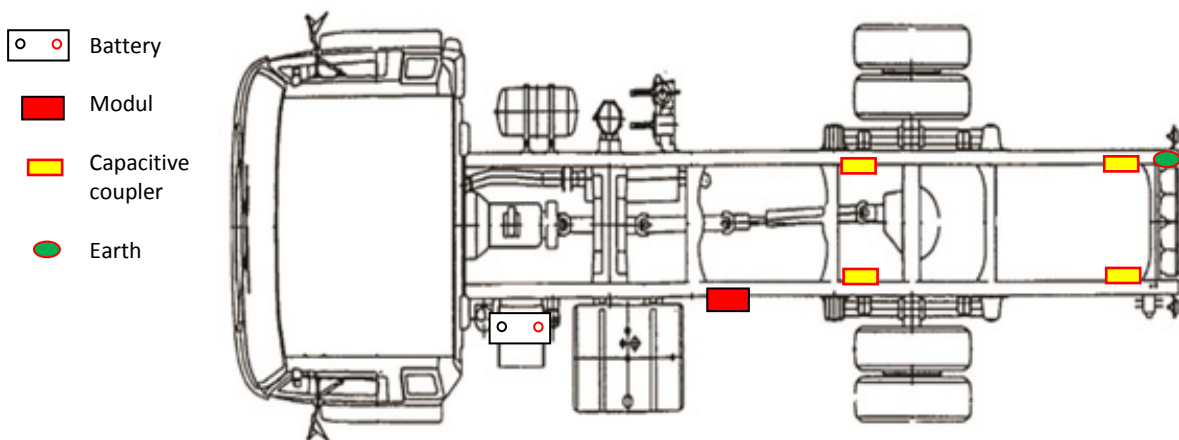

**IMPORTANT INFORMATION:** Be sure to avoid positioning wires too close to hot or moving parts that may melt or pinch the wires. Protect all wiring with split loom. Ensure that all wiring cannot be damaged or torn off in normal working environments. Secure all wiring firmly with cable ties or equivalent alternative.

### Step 11: Check Installation

Check all wiring connections to ensure that they are secure and sealed correctly.

Ensure that the Capacitive Couplers are all affixed to the body/chassis of the vehicle.

### Step 12: Insert the Fuse

Insert the fuse into the fuse holder and observe the modules LED's to confirm Normal Operation Mode (refer Modes of operation).

## Modes of operation

The Module has three modes of operation, which are:

### 1. Start-up Mode

When the system is started using a 12V Power Supply: The modules Green LED will illuminate for 30 seconds whilst the system configures itself.

When the system is started using a 24V Power Supply: The Green LED on the module will illuminate for 10 seconds, this will be followed by the Red LED illuminating for 30 seconds whilst the system configures itself.

### 2. Normal Operation Mode

The modules Green LED will flash continuously confirming that the system is functioning correctly.

### 3. Fault Mode

The modules Red LED will flash upon the detection of a fault. The fault indicators are:

- Red LED flashing continuously: This indicates that the module has detected a Dead Short on Channel A - White Capacitive Coupler wiring. In this instance Channel A will be shut down, but Channel B will continue to function.
- Red LED flashing continuously with the Green LED constantly illuminated: This indicates that the module has detected a Dead Short on Channel B - Blue Capacitive Coupler wiring. In this instance Channel B will be shut down, but Channel A will continue to function.
- Red & Green LEDs flashing together 10 times every 30 seconds: This indicates Low Battery, meaning that the vehicles battery level has dropped below the minimum input requirement and that the module has shut itself down to protect the battery.

(FIGURE: 7):

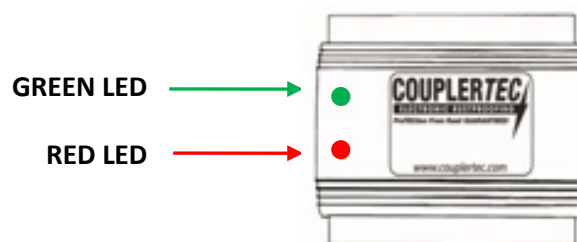



## Fitting the Capacitive Coupler

Thoroughly clean the site where the Capacitive Coupler is to be located using the alcohol cleaning pad. Remove any oil, wax or dirt. For extremely dirty sites, use white spirits or similar with a rag to clean the site, followed by the use of the alcohol cleaning pad.

Before affixing the Capacitive Coupler, ensure that all joints between the module and Capacitive Coupler have been completed.

Once the site is clean and dry peel off the backing paper from the back of the Capacitive Coupler ready to secure (don't touch the adhesive surface). The Capacitive Coupler must be affixed in an upright position with the wire facing downwards (refer figure 8), firmly press the Capacitive Coupler onto the prepared site making sure that there are no bubbles under the Capacitive Coupler. The Capacitive Coupler must be 100% in contact with the painted metal surface.

### **IMPORTANT INFORMATION:**

**DO NOT install the Capacitive Coupler in an upside down position. Always install the Capacitive Coupler with the wire facing towards the ground.**

**If you are locating Capacitive Couplers on the underside of the vehicles body or chassis rails, or other areas that may potentially be exposed to water, then you must; completely dome over the entire Capacitive Coupler including the wire with a Neutral Cure Silicone Sealant ensuring that the edges of the Capacitive Coupler are sealed to the paintwork.**

(FIGURE: 8)

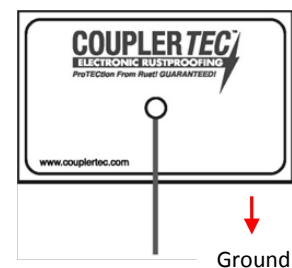

## Fitting the Capacitive Coupler

Turn the Capacitive Coupler Cover upside down (refer Figure: 9). Completely fill the inside of the Capacitive Coupler Cover with a Neutral Cure Silicone.

(FIGURE: 9)

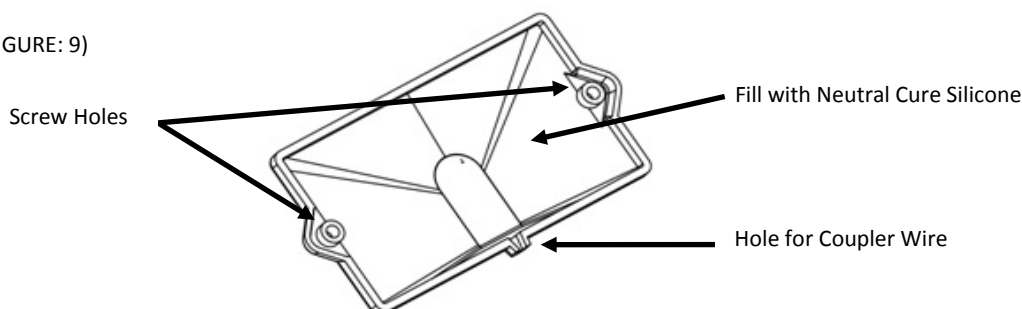

Turn the Capacitive Coupler Cover upright and push the cover over the Capacitive Coupler ensuring that the wire runs through the hole in the cover. Press down firmly until the Cover is flush with the painted surface.

Run a bead of silicon around the border of the Capacitive Coupler Cover to completely waterproof. Use the Hex Head Self Tapping Screws to secure the Capacitive Coupler Cover to the body of the vehicle.

**WARNING: Do NOT use the screws in areas where the screws will penetrate to the outside of the vehicle. Ensure that there is nothing behind the location that can be damaged by the self-tapping screws which will used to secure the cover to the vehicle.**